

RIGHT ANGLE JACK CRIMP TYPE

R120.354.500

CABLE 2.6/50 S

Series : **DIN 41626**

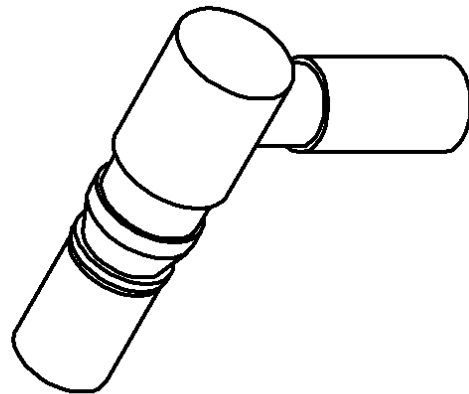
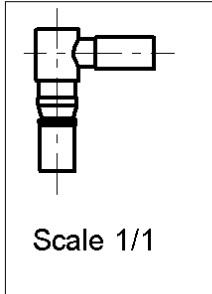
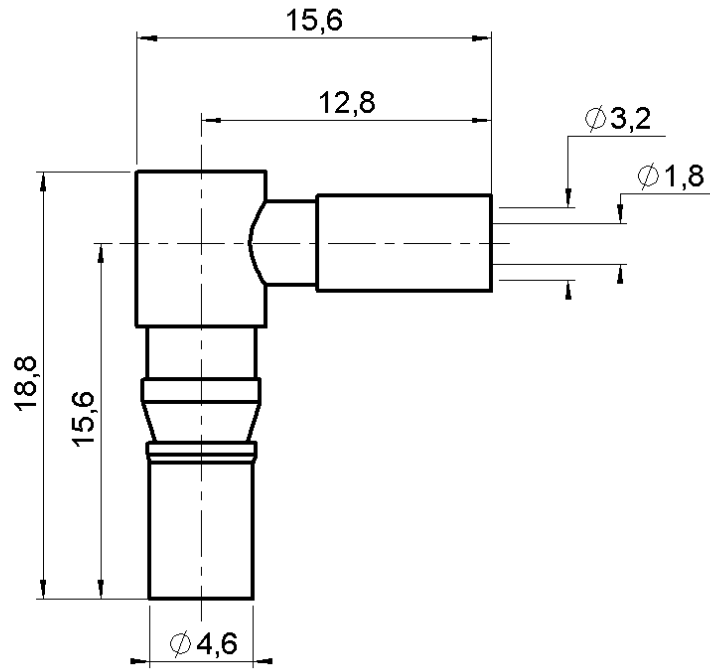

All dimensions are in mm.

COMPONENTS	MATERIALS	PLATINGS (µm)
BODY	BRASS	GOLD .
CENTER CONTACT	BERYLLIUM COPPER	GOLD .
OUTER CONTACT	BRASS	GOLD .
INSULATOR	PTFE	
GASKET	-	
OTHERS PARTS	-	
-	-	
-	-	

Issue : 0048 B

In the effort to improve our products, we reserve the right to make changes judged to be necessary.



RIGHT ANGLE JACK CRIMP TYPE

R120.354.500

CABLE 2.6/50 S

Series : **DIN 41626**

PACKAGING

Standard	Unit	Other
100	'W' option	Contact us

SPECIFICATION

ELECTRICAL CHARACTERISTICS

Impedance		50	Ω
Frequency		0-2	GHz
VSWR	1.4 +	0.000	x F(GHz) Maxi
Insertion loss		NA	\sqrt{F} (GHz) dB Maxi
RF leakage	- (NA	- F(GHz)) dB Maxi
Voltage rating		250	Veff Maxi
Dielectric withstanding voltage		750	Veff mini
Insulation resistance		1000	M Ω mini

CABLE ASSEMBLY

Stripping	a	b	c	d	e	f
mm	1.00	7.00	12.0	0.00	11.0	0.00

Assembly instruction :

Recommended cable(s)
 KX 22A
 RG 316
 RG 188

Cable retention

- pull off **40** N mini
- torque **NA** N.cm

MECHANICAL CHARACTERISTICS

Center contact retention			
Axial force – Mating end		10	N mini
Axial force – Opposite end		10	N mini
Torque		NA	N.cm mini

TOOLING

Part Number	Description	Hexagon
.	.	.
R282.211.000	CRIMPING TOOL	3.25
R282.235.003	CRIMPING DIES	3.25
R282.293.000	CRIMPING TOOL	-

Recommended torque			
Mating		NA	N.cm
Panel nut		NA	N.cm
Clamp nut		NA	N.cm
A/F clamp nut		0.000	mm

Mating life		100	Cycles mini
Weight		2.350	g

OTHERS CHARACTERISTICS

-

ENVIRONMENTAL

Operating temperature		-55/+155	$^{\circ}$ C
Hermetic seal		NA	Atm.cm3/s
Panel leakage		NA	

Issue : **0048 B**

In the effort to improve our products, we reserve the right to make changes judged to be necessary.



RIGHT ANGLE JACK CRIMP TYPE

R120.354.500

CABLE 2.6/50 S

Series : DIN 41626

COMPONENTS

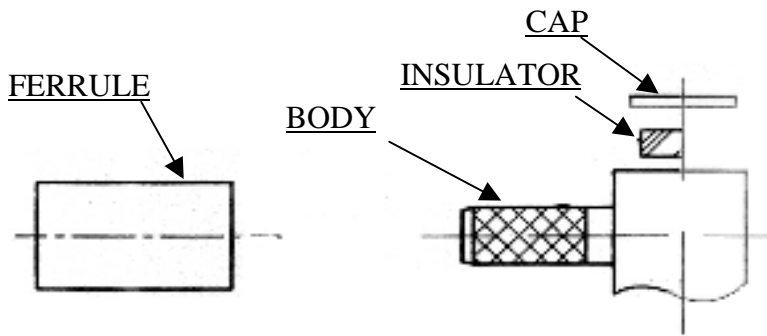

STRIPPING DIMENSIONS

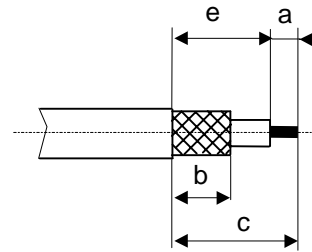

1

- Slide the ferrule onto the cable.
- Strip the cable .

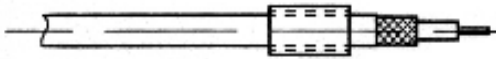

3

- Crimp the ferrule with crimping tool .
- Solder inner conductor.

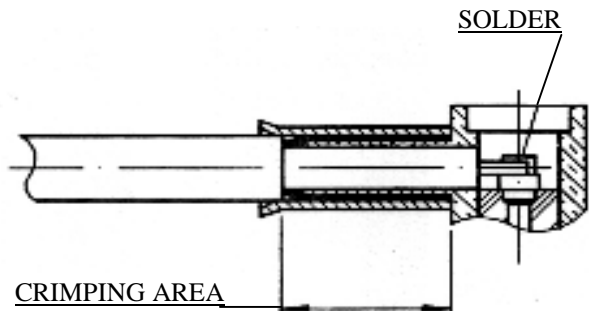

2

- Fan the braid.
- Push connector body under the braid.
- Slide the ferrule on the braid (in direction F)

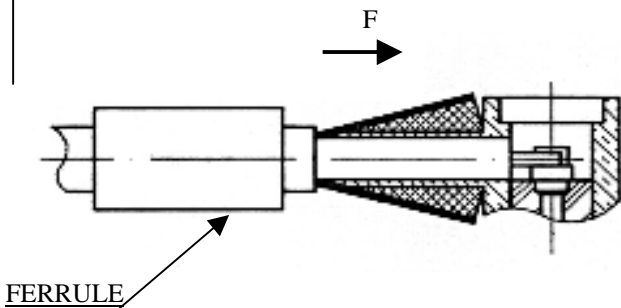

4

- Place insulator into body.
- Place and solder the cap.

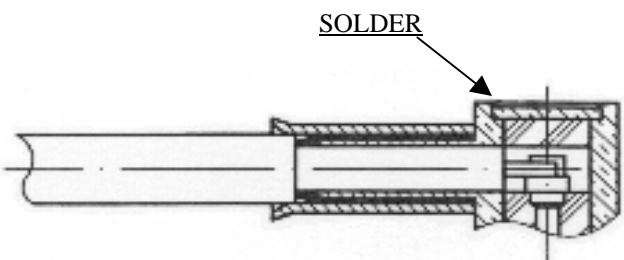

Issue : 0048 B

In the effort to improve our products, we reserve the right to make changes judged to be necessary.

